

## DYNAMIC RESPONSE OF VEHICLE CONSIDERING AXLE FLEXIBILITY TRAVELLING OVER SERIES OF POTHOLES

S. Reddy and S. Talukdar

Department of Civil Engineering, Indian Institute of Technology Guwahati, India

### ABSTRACT

In the present paper, the dynamic response of the vehicle passing over a series of pothole has been obtained analytically. Axle flexibility has been considered in the model of vehicle. The suspension stiffness and damping have been assumed to be linear. The truck is modeled as a combination of lumped and distributed parameter system with the axle of the vehicle idealized as Euler Bernoulli beam. The system equations after recasting into state space form have been decoupled using complex modes. Parametric study has been conducted to examine the influence of pothole parameters and vehicle velocity on the dynamic amplification factor (DAF) of the vehicle response. In the study, it has been noticed that when vehicle crosses series of potholes of similar character at regular interval, the response tends to be in steady state after crossing initial few potholes. For a certain pothole width, a critical velocity exists to determine maximum response in the vehicle.

**Keywords:** Dynamic Response, Axle Flexibility, Potholes

### 1. INTRODUCTION

The conditions of road are very much important to determine the passenger's safety and comfort, vehicle fuel cost and its maintenance. It is important to find the response of vehicles when come across by various irregularities existing on the road to facilitate the safe design of suspension and to impose speed and weight restrictions over such roads. It may be mentioned that high dynamic force imposed on the pavement and its cumulative effect are responsible for fatigue failure of the pavement. The poor road conditions increases the dynamic tyre force on the pavement, causing deterioration of the road pavement.

With heavy traffic flow over the poorly constructed roads accompanied by unfavorable environmental and sub grade soil conditions, several potholes on the roads may be created. Without maintenance these potholes grow in size causing nuisance in the driving. Vehicle wheels falling on the potholes experiences high dynamic input which brings discomfort to the passengers; causes damage to the vehicle components and may affect stability and control of the vehicle at high speed movement. Considering the practical importance of topic, research has been carried out to determine vehicle response moving over rough roads modeling roughness as deterministic and Gaussian random process [1-4]. The report on pothole induced contact forces was published by Peterev and Bergman [5] and also by Peterev et. al [6] where they considered simple quarter car model without suspension damping. It has been shown that the dependence of the magnitude of the dynamic force on

pothole width, oscillator eigen-frequency and velocity is described by a simple function of one variable called the dynamic amplification factor (DAF) for the pothole. Most of the earlier researches were focused on the rigid vehicle model excited by the road irregularity continuous along the stretch of road pavement. The potholes which represent discrete roughness at arbitrary location and of arbitrary size are more severe than continuous irregularity of smaller magnitudes. In the present days, vehicle length has increased to accommodate more pay loads. As such, the vehicles may undergo not only rigid body motions but also elastic deformation. An improved vehicle model with axle flexibility has been considered in the present work for the response analysis. A closed form expression has been derived using Duhamel's integral. Parametric studies have been conducted to examine the effect of vehicle and road parameters on the response of the vehicle.

### 2. PROBLEM FORMULATION

#### 2.1 Pothole Model

A vehicle, traveling on road consisting of several isolated irregularities experiences large dynamic input when speeding wheel falls on it. The type of irregularity is referred as 'pothole' in this paper. The pothole function may be expressed in the form

$$r(x) = -\frac{a}{2} \left( 1 - \cos \frac{2\pi x}{b} \right) \text{ for } 0 < x < b$$
$$= 0 \text{ for } x < 0, x > b \quad (1)$$

where  $a$  and  $b > 0$  are the pothole "depth" and "width", respectively (negative values of  $a$  correspond to bumps)

## 2.2 Vehicle Model

A vehicle model considered in the study consisting of sprung mass supported by axles, which are flexible members and prone to be bent under large dynamic force encountered while wheel at large velocity falls on the potholes. The model of the vehicle and the track is shown in Fig.1. The axle shown in Fig. 1 is an Euler Bernouli beam carrying half of the Sprung mass  $M_v$  in addition to its own mass  $m$  kg/m. Tyre masses  $m_{t1}$  and  $m_{t2}$  are assumed to be connected to the vehicle through suspension systems, characterized by linear stiffness and damping parameters ( $K_1, C_1; K_2, C_2$ ) corresponding to left and right tyre. The subscripts 1 and 2 refer to the left and right tyre respectively.

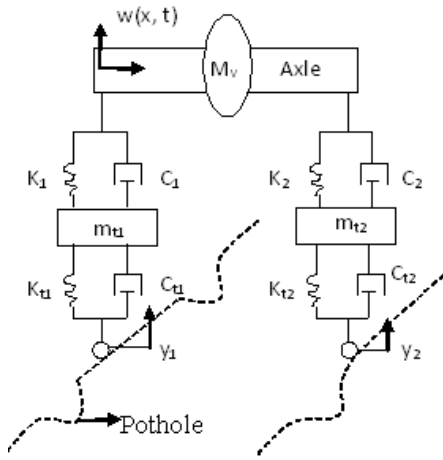

Fig.1 Model of a Vehicle

## 2.3 System Equations

The equation of motion of axle idealized as beam carrying vehicle mass and subjected to suspension forces at two attachment points are given by

$$EI \frac{\partial^4 w}{\partial x^4} + m \frac{\partial^2 w}{\partial t^2} + c \frac{\partial w}{\partial t} = f(x, t) - M_v \frac{\partial^2 y}{\partial t^2} \delta(x - L/2) \quad (2)$$

where  $EI$ =flexural rigidity,  $m$  =mass/length;  $c$ =damping/length of the axle,  $w(x, t)$  is the transverse displacement,  $L$  is the length of the axle,  $f(x, t)$  is the impressed force given by

$$\begin{aligned} f(x, t) &= f_1 \delta(x - x_1) + f_2 \delta(x - x_2) \\ f_1(x, t) &= K_1(z_1 - w(x, t)) + C_1(\dot{z}_1 - \dot{w}(x, t)) \\ f_2(x, t) &= K_2(z_2 - w(x, t)) + C_2(\dot{z}_2 - \dot{w}(x, t)) \end{aligned} \quad (3)$$

$x_1$  and  $x_2$  represent the points on axle at which a point force will be acting due to the vertical vibration of tyre masses. ' $\delta$ ' denotes Dirac delta function.

The equations of motion of the two lumped tyre masses along the vertical direction are

$$\begin{aligned} m_i \ddot{z}_i + K_i(z_i - w(x_i, t)) + C_i(\dot{z}_i - \dot{w}(x_i, t)) + \\ K_{ti}(z_i - y_i) + C_{ti}(\dot{z}_i - \dot{y}_i) = 0 \end{aligned} \quad (4)$$

( $i=1, 2$ )

## 3. SOLUTION TECHNIQUE

Assuming modal superposition principle, the axle displacement can be expressed as

$$w(x, t) = \sum_{i=1}^{\infty} \Phi_i(x) \eta_i(t) \quad (5)$$

where  $\Phi_i(x)$  is the  $i$ th normal mode and  $\eta_i(t)$  is the corresponding normal coordinate. The natural frequencies and mode shape function for free-free beam can be obtained as

$$\omega_i = (\beta_i L)^2 \sqrt{\frac{EI}{mL^4}} \quad (6)$$

Where  $\omega_i$  is the  $i$ th natural frequency and  $\beta_i L$  is non dimensional frequency parameters that have to be obtained from the mode shape function [7] given below

$$\Phi(x) = A \cosh \beta x + B \cos \beta x + C \sinh \beta x + D \sin \beta x \quad (7)$$

$A, B, C$  and  $D$  are constants of integration to be determined after applying boundary conditions.

Using eq.(5) in (2), then multiplying the resulting equation by  $\Phi_k$ , and thereafter integrating in the domain of the beam making use of orthogonality property of the normal modes, one obtains the discretized equations for the axle as below

$$\ddot{\eta}_i(t) + 2\zeta_i \omega_i \dot{\eta}_i(t) + \omega_i^2 \eta_i(t) = Q_i(t) \quad (8)$$

where

$$Q_i(t) = \frac{1}{M_i} \int_0^L f(x, t) \phi_i(x) dx - \frac{M_v}{M_i} \int_0^L \phi_i(x) \sum_{i=1}^3 \phi_i(x) \ddot{\eta}_i(t) \delta(x - L/2) dx \quad (9)$$

$f(x, t)$  is same as defined in eqn. (3) and  $M_i$  is the generalized mass given by

$$M_i = \int_0^L m \phi_i^2(x) dx \quad (10)$$

Considering, first  $j$  modes of vibration of the axle, eqs. (4) and (8) can be arranged in matrix form, as given below

$$[M]\{\ddot{q}\} + [C]\{\dot{q}\} + [K]\{q\} = \{F\} \quad (11)$$

Where  $\{q\}$  are response vector whose dimension is  $n=(j+2) \times 1$  will be  $\{q\}^T = \{\eta_1, \eta_2, \dots, \eta_j, z_1, z_2\}$  and generalized force vector  $\{F\}$  contain the pothole functions, being the source of dynamic excitation. The order of mass, stiffness and damping matrices are of order  $(j+2) \times (j+2)$ . The system eq.(9) can be cast into state space form in  $2(j+2)$  dimensional matrices [8]

$$\{\dot{p}(t)\} + [G]\{p(t)\} = \{P(t)\} \quad (12)$$

Where

$$\{p(t)\}^T = \{\dot{\eta}_1, \dot{\eta}_2, \dots, \dot{z}_1, \dot{z}_2, \eta_1, \eta_2, \dots, z_1, z_2\} \quad (13)$$

$$\{P(t)\}^T = \{[M]^{-1}\{F(t)\} \quad 0\} \quad (14)$$

$$[G] = \begin{bmatrix} M^{-1}C & M^{-1}K \\ -I & 0 \end{bmatrix} \quad (15)$$

$I$  is an identity matrix. Using the complex eigen values and eigen vectors of the matrix  $[G]$ , the eq.(12) can be decoupled as

$$\dot{v}_i(t) + \alpha_i v_i(t) = R_i \quad (16)$$

$$\text{Where } \{R(t)\} = [U]^{-1} \{F(t)\} \quad (17)$$

where  $[U]$  is the modal matrix formed by arranging the eigen vectors  $\{u\}_i$  (corresponding to eigenvalue  $\alpha_i$ ) in  $i$ th column and  $v_i$  is  $i$ th generalized co-ordinate. Along the stretch of the road at any instant  $t_i$  of time, the distance of the  $i$ th wheel of the vehicle given by  $x_i = Vt_i$ , in which  $V$  is the velocity of the vehicle. The response of the linear system's generalized co-ordinate subject to initial condition and forced excitation can be found using Duhamel integral [7] as follows

$$v_i(t) = A_0 e^{-\alpha_i t} + \sum_{j=1}^{2n} \sum_{k=1}^{2n} \bar{u}_{ij} m_{ik} \int_0^t F(\tau) h(t-\tau) d\tau \quad (18)$$

in which  $h(t)$  is the unit impulse function,  $A_0$  is the initial condition of the  $i$ th generalized co-ordinate,  $\bar{u}_{ik}$  is  $i$ th element of the eigenvector corresponding to  $k$ th mode. It may be noted that vehicle is subjected to forced vibration when wheels fall on the pothole. After crossing the pothole at time  $t_1 = b/V$  (here,  $V = \text{constant velocity of the vehicle}$ ,  $b = \text{width of the pothole}$ ), free vibration state occurs due to initial conditions at  $t = t_1$ . Same condition is repeated in case of other potholes. On integration of the eq. (18), time domain response of the generalized co-ordinate of the axle has been found as

$$\begin{aligned} v_i(t) = & A_0 e^{-\alpha_i t} + \sum_{j=1}^{2n} \sum_{k=1}^{2n} \bar{u}_{ij} m_{ik} e^{-\alpha_i t} \times \\ & \left[ \frac{-aK_{t1}}{2\alpha_i} \{e^{\alpha_i(t-T_{1n})} - e^{-\alpha_i T_{1n}}\} - \frac{aC_{t1}\beta}{\alpha_i^2 + \beta^2} \times \right. \\ & \{e^{\alpha_i(t-T_{1n})} (\alpha_i \sin \beta(t-T_{1n}) - \beta \cos \beta(t-T_{1n}))\} \\ & + e^{-\alpha_i T_{1n}} (\alpha_i \sin \beta T_{1n} - \beta \cos \beta T_{1n}) \\ & + \frac{aK_{t2}}{2\alpha_i} \{e^{-\alpha_i(t-T_{2n})} - e^{-\alpha_i T_{2n}}\} + \frac{aC_{t2}}{2(\alpha_i^2 + \beta^2)} \times \\ & \{e^{\alpha_i(t-T_{2n})} (\alpha_i \sin \beta(t-T_{2n}) + \beta \cos \beta(t-T_{2n}))\} \\ & \left. - e^{-\alpha_i T_{2n}} (\alpha_i \sin \beta T_{2n} + \beta \cos \beta T_{2n}) \right] \quad (19) \end{aligned}$$

where  $T_{1n}$  and  $T_{2n}$  are the times at which  $n$ th and  $n$ 'th pothole are encountered by the left and right wheels respectively and  $\beta = 2\pi v/b$ . After finding  $v_i$ , the state vector  $\{p\}$  can be obtained and using those with mode shape function of the flexible axle in eq.(5), the axle response  $w(x,t)$  and its derivatives can be completely determined.

#### 4. RESULTS AND DISCUSSIONS

To illustrate the approach outlined in the paper, numerical results are obtained adopting following data:

Mass of Axle per unit length  $m = 250$  kg, Length of axle  $L = 2$  m, Velocity of vehicle  $V = 15$  m/s, Mass of vehicle body  $M_v = 2000$  kg, Mass of tyres =  $m_{t1} = m_{t2} = 8$  kg, Tyre stiffness  $K_{t1} = K_{t2} = 1.7 \times 10^4$  N/m, Tyre damping  $C_{t1} = C_{t2} = 1 \times 10^2$  Ns/m, Suspension stiffness  $K_1 = K_2 = 1.6 \times 10^6$  N/m, Suspension damping  $C_1 = C_2 = 1 \times 10^4$  N/m Pothole depth (a) = 0.01m, Pothole width (b) = 0.5 m.

#### 4.1 Time History of Response

Response (displacement) of the axle centre of gravity has been presented (i) when pothole spacing is taken uniform and (ii) also random. In case (i), 12 potholes both along left and right wheel path uniformly spaced at 20 m has been considered, the results being shown in Fig.2

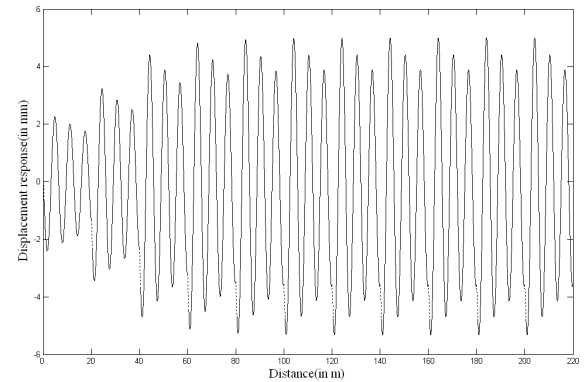

Fig 2. Time history of Displacement of axle c.g for twelve potholes at uniform spacing.

It may be observed that for initially few potholes (four in the present case), amplitude of vibration goes on increasing. However, it is of interest to note that response magnitude exhibits steady state pattern when number of potholes crossed is more than five. The trend of the result conforms to the periodicity in the excitation, since spacing of potholes are taken as uniform in the present case. For the case (ii), random potholes spacing to be used in time response has been generated for 12 potholes, taking mean spacing 20 m and standard deviation 5m. It has been assumed that spacing of potholes follow the Gaussian distribution. The mean time history of 20 trials has been presented in Fig.3

The response of the axle c.g for potholes at random distances is not found to follow any particular pattern. The response of the vehicle after crossing the pothole is found to decrease as in the case of free vibration stage in presence of damping. No periodicity can be ascertained in this case.

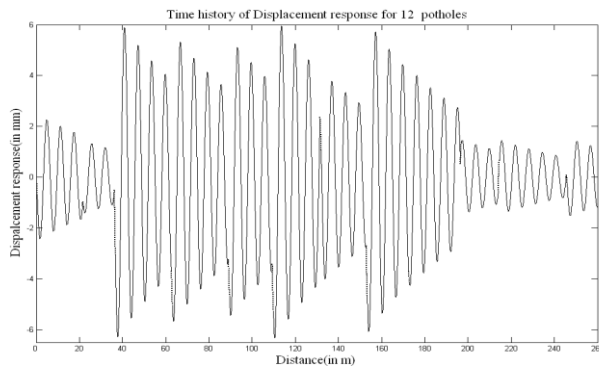

Fig 3. Time history of Mean Displacement of axle c.g twelve potholes at random spacing

#### 4.2 Dynamic Amplification Factor

Dynamic Amplification Factor (DAF) in the present case has been calculated as ratio of absolute maximum of static plus dynamic displacement to the static displacement of the axle c.g. The effect of various parameters on the DAF has been investigated.

##### 4.2.1 Effect of vehicle velocity

A plot between velocity and DAF for two different values of damping ratio is presented in Fig.4. The dependence of DAF on velocity is shown by taking all other variables constant, and by varying velocity of vehicle ( $v$ ) from  $v = 10$  m/s to 30 m/s. Two different pothole widths 0.5 m and 0.7 m have been considered. It can be noted that DAF increases with increase in velocity of vehicle up to a velocity of 23m/s and the decreases with further increase in velocity for pothole width of 0.5m. The fact that DAF becomes maximum at certain velocity is due to the occurrence of resonance at the particular ground frequency. Thereafter amplification factor reduces because of separation of ground frequency from the vehicle bounce mode. For higher damping of suspension DAF is lower but follows same trend. DAF when computed with pothole width 0.7 m is shown in Fig.5 for the same range of vehicle velocity as before. It may be noted for larger pothole width, maximum amplification may occur at greater velocity compared to pothole of smaller width. A critical velocity for a particular vehicle of known suspension characteristics therefore can be found for certain pothole width.

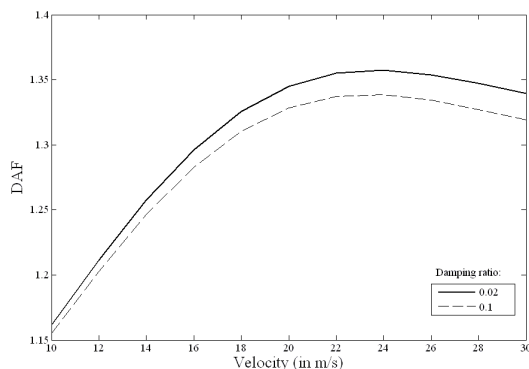

Fig 4. Effect of vehicle velocity on DAF on small pothole

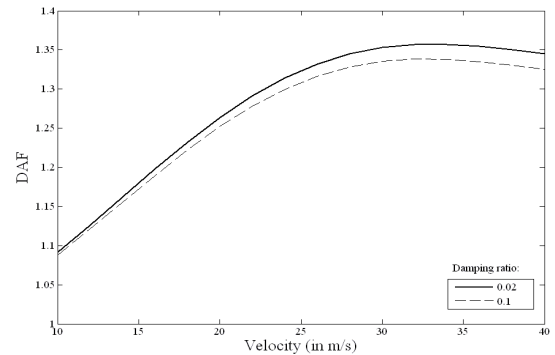

Fig 5. Effect of vehicle velocity on DAF larger pothole.

##### 4.2.2 Effect of Random Spacing of potholes

A study has been conducted to find the effect of pothole spacing on the dynamic response of the vehicle. For randomly spaced potholes, mean spacing and standard deviations are taken as influencing parameters. Fig.6 presents DAF with the variation of mean pothole spacing, standard deviation being taken constant as 5 m.

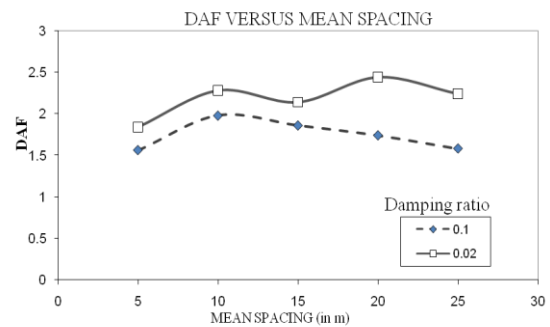

Fig 6. Effect of mean pothole spacing on the DAF (pothole width=0.5 m)

Results have been presented for two different dampings of the axle beam. It has been seen that for higher damping, amplification of the statical displacement, becomes less as pothole spacing increases beyond 15m. For distant location of the next hole, substantial decay of the motion might have taken place during free vibration phase and therefore, in a relatively short time of crossing next pothole, static response could not have magnified.

##### 4.2.3 Effect of width of pothole

Fig.7 represents the variation of dynamic amplification factor with the width of the vehicle for two different damping ratios. The higher damping shows less amplification although increase of pothole width increases the amplification. This may be attributed to the excitation lasting for longer time than that for a pothole of smaller width. The result demonstrates that the pothole width is significant parameter for ride comfort and road management.

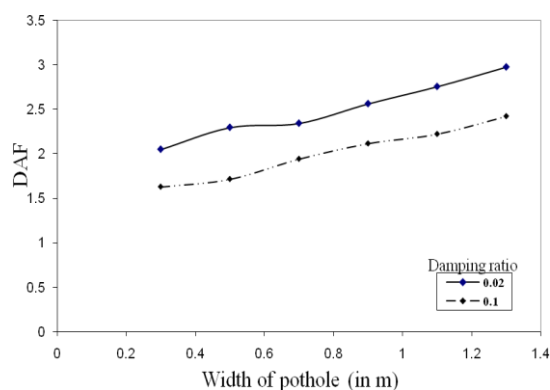

Fig 7. Effect of the width of the pothole on DAF

#### 4.3 DAF, Peak Acceleration and Jerk

The riding comfort can be judged in a better way from the value of peak jerk. (rate of change of acceleration). Liu and Herman [9] has described how road profile could influence vehicle dynamics and ride quality rating. In the present paper, DAF for a particular vehicle speed, corresponding peak acceleration and jerk have been presented in Table-1. Pothole width of 0.5 m @ 20 m c/c and number of potholes are taken as four for comparative study.

Table 1 : DAF, Peak Acceleration and Jerk for different vehicle speed

Vehicle speed (m/s)	DAF	Peak Acceleration (m/s <sup>2</sup> )	Peak Jerk (m/s <sup>3</sup> )
12	1.19	0.012	2.34
16	1.26	0.014	2.85
20	1.30	0.015	3.47
24	1.32	0.015	3.88
28	1.32	0.016	3.92

The three parameters have been obtained by increasing the speed of the vehicle from 12 m/s to 28 m/s. Other vehicle parameters are kept constant for generating the results. There is an overall increase of 11.0 percent in DAF and 33.0 percent in peak acceleration whereas increase of peak jerk has been found up to 67.5 percent for the present analysis. It is known that humans are sensitive to changes of force and the change of force per unit time induces jerk. Thus parameter jerk would be a better indicator of riding comfort.

#### 5. CONCLUSIONS

The response of the vehicle shows that for uniformly spaced vehicle a periodicity may be reflected in the dynamic behavior. However, the period and hence

resonance may be governed by the vehicle velocity. In case of randomly spaced potholes, the DAF decreases as mean spacing of potholes increases. Parametric study indicates that increasing damping of vehicle suspension decreases DAF for any size of the pothole. For larger width of pothole, maximum dynamic amplification occurs at greater vehicle velocity compared to pothole of smaller width. However, any kind of periodicity produced by the pothole geometry and spacing has to be verified by the automobile designer to prevent large amplitude at resonance. On examination of sensitivity of DAF, peak acceleration and jerk on ride quality, it may be concluded; 'jerk' is the most suitable indicator for ride comfort. This is significant for the safety of passengers, cargo and fatigue life of the vehicle. The purpose of this kind of research is to highlight the need of periodical road maintenance, restriction of payload over the road/bridge for overall safety of vehicle and passengers.

#### 6. REFERENCES

1. Wong, J. K., 1978 "Theory of Ground Vehicles", John Wiley and Sons
2. Dodds, C. J. and Robson, J. D., 1973 "The description of road surface roughness", *Journal of Sound and Vibration* 31, 175-183
3. Heath, A. N., 1987, "Application of the isotropic road roughness assumption", *Journal of Sound and Vibration*, 115, 131-144
4. Talukdar, S, 1997 'Spectral analysis of pavement surface' *Highway Research Bulletin*, IRC, 59, 99-108
5. Pesterev, A.V. Bergman, L.A., Tan, C..A., 2002, "Pothole-induced contact forces in a simple vehicle model", *Journal of Sound and Vibration* 256, 565-572.
6. Pesterev, A.V. Bergman, L.A., Tan, C.A and Yang, B, 2005 "Assessing tire forces due to roadway unevenness by the pothole dynamic amplification method", *Journal of Sound and Vibration* 279, 817-841.
7. Meirovitch, L., 1986, "Elements of Vibration Analysis", 1986, Mc. Graw Hill
8. Nigam, N. C., 1983, "Introduction to Random Vibration", MIT Press, Cambridge.
9. Liu, C. and Herman, R., 1999, "Road profile, Vehicle Dynamics and Ride Quality Rating". *Journal of Transportation Engineering*, ASCE, 125, 123-128

#### 7. MAILING ADDRESS

**S. Reddy**

Former Undergraduate student, Department of Civil Engineering

Indian Institute of Technology Guwahati, India